

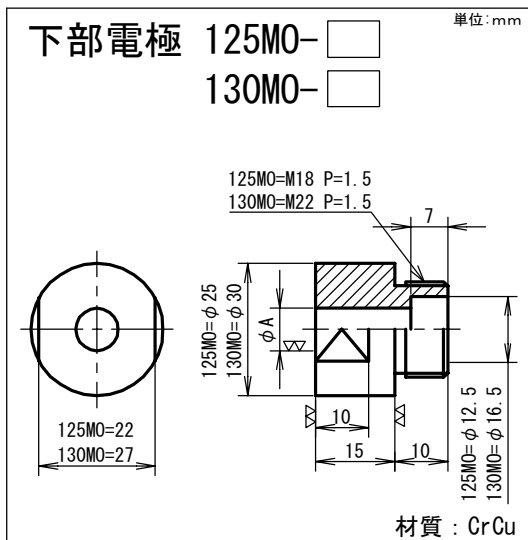

ELECTRODERS FOR PROJECTION WELDING NUTS

プロジェクションナット電極

standard type



CDNo.	規格	A
AA0001	下部電極 125MO-14K	4.9
AA0002	下部電極 125MO-14	5.1
AA0003	下部電極 125MO-15K	5.9
AA0004	下部電極 125MO-15	6.1
AA0017	下部電極 125MO-16M	6.6
AA0005	下部電極 125MO-16K	6.9
AA0006	下部電極 125MO-16	7.1
AA0007	下部電極 125MO-18K	8.9
AA0008	下部電極 125MO-18	9.1
AA0009	下部電極 130MO-110K	10.9
AA0010	下部電極 130MO-110	11.1
AA0011	下部電極 130MO-111K	11.9
AA0012	下部電極 130MO-111	12.1
AA0013	下部電極 130MO-112K	12.9
AA0014	下部電極 130MO-112	13.1

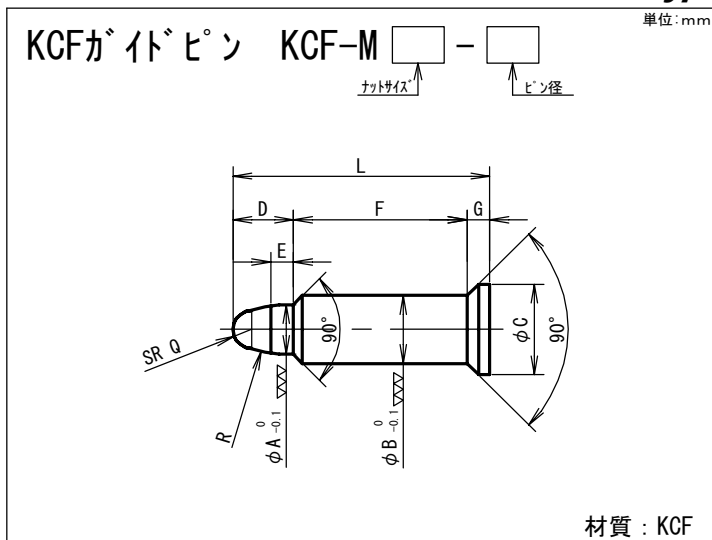

CDNo.	規格	A	B	C	D	E	F	G	R	Q	L
331011	KCF-M4-4.8	3.2	4.8	10	5	2	22	4	9	2.5	31
331012	KCF-M4-5.0		5.0								
331013	KCF-M5-5.8	4.1	5.8	10	6	2.5	22	4	13.3	3	32
331014	KCF-M5-6.0		6.0								
331015	KCF-M6-6.5		6.5								
331016	KCF-M6-6.8	4.9	6.8	10	7	2.5	22	3	15.5	3.5	32
331017	KCF-M6-7.0		7.0								
331018	KCF-M8-8.8	6.6	8.8	12	8	3	23	3	17.5	5	34
331019	KCF-M8-9.0		9.0								
331020	KCF-M10-10.8	8.5	10.8	15	10	3.5	24	3	30.5	7	37
331021	KCF-M10-11.0		11.0								
331022	KCF-UNF-11.0		11.0								
331023	KCF-UNF-11.8	9.7	11.8	16	12	4	24	3	37.5	8	39
331026	KCF-UNF-12.0		12.0								
331024	KCF-M12-12.8	10.4	12.8	16	12	4	24	3	41	9	39
331025	KCF-M12-13.0		13.0								

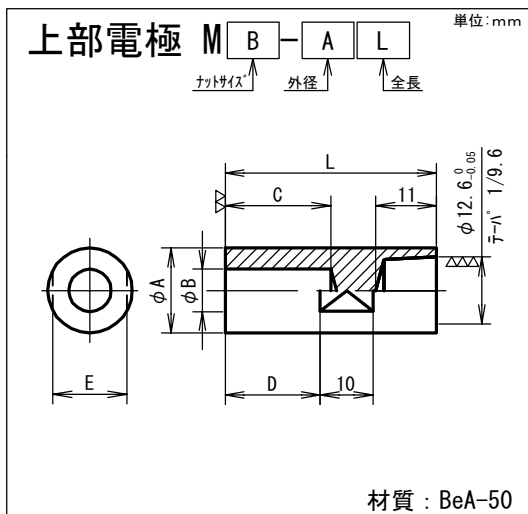

CDNo.	規格	A	B	C	D	E	L
JB0001	上部電極 M4-1640	16	4	20	18	14	40
JB0002	上部電極 M5-1640	16	5	20	18	14	40
JB0003	上部電極 M6-1640	16	6	20	18	14	40
JB0004	上部電極 M8-1640	16	8	20	18	14	40
JB0005	上部電極 M10-2048	20	10	30	23	17	48
JB0006	上部電極 M12-2548	25	12	30	23	22	48

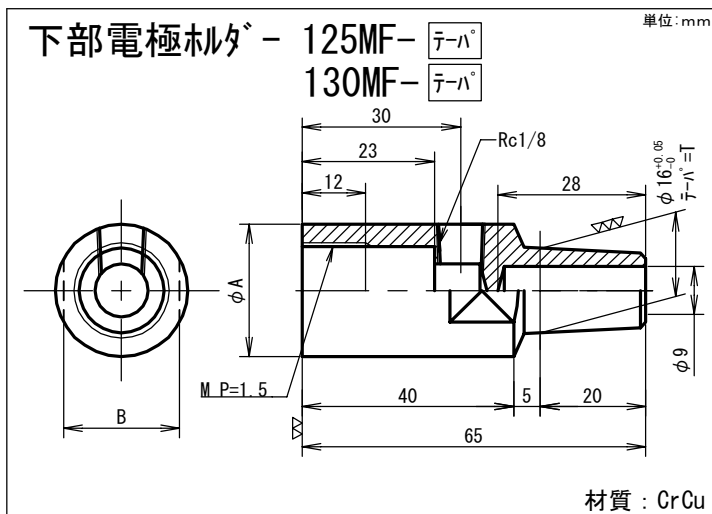

CDNo.	規格	A	B	M	T
AA1001	下部電極 <input type="checkbox"/> - 125MF-16 1/5	25	22	M18	1/5
AA1002	下部電極 <input type="checkbox"/> - 125MF-16 1/10	25	22	M18	1/10
AA1003	下部電極 <input type="checkbox"/> - 130MF-16 1/5	30	27	M22	1/5
AA1004	下部電極 <input type="checkbox"/> - 130MF-16 1/10	30	27	M22	1/10



ELECTRODERS FOR PROJECTION WELDING NUTS

プロジェクションナット電極

W type

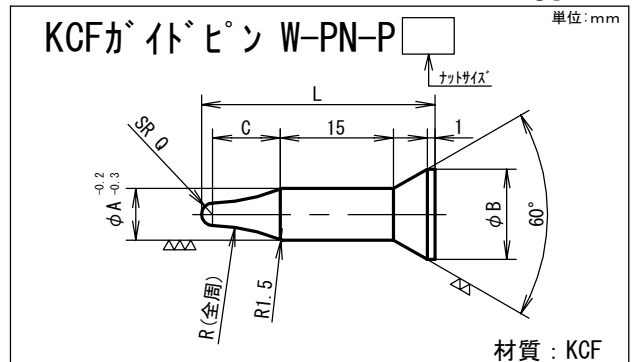
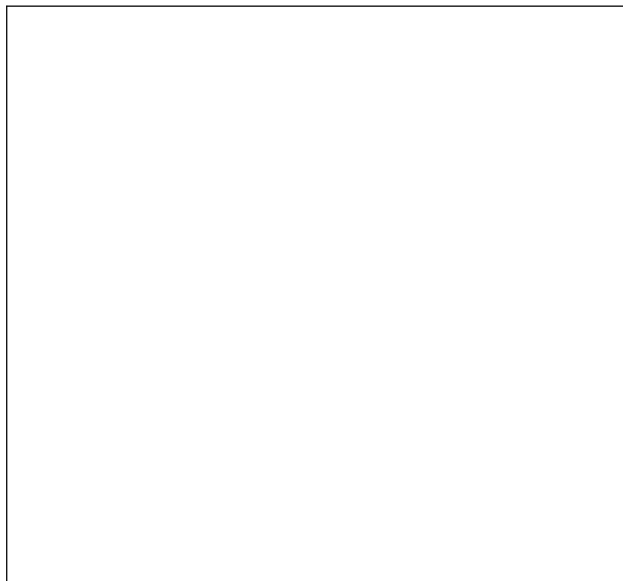

CDNo.	規格	A	B	C	R	Q	L
331001	KCFガイドピン W-PN-P4	5	12	5.5	11.0	2	28.7
331002	KCFガイドピン W-PN-P5	6	12	7.5	15.0	2	29.8
331003	KCFガイドピン W-PN-P6	7	12	9.5	23.6	3	30.9
331004	KCFガイドピン W-PN-P8	9	12	11	21.7	3	31.1
331005	KCFガイドピン W-PN-P10	11	16	12	22.3	4	34.4
331006	KCFガイドピン W-PN-P12	13	16	15	27.0	4	35.7

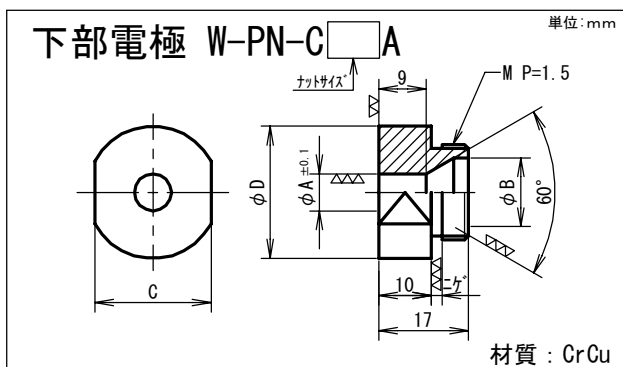

CDNo.	規格	A	B	C	D	M
AA0041	下部電極 W-PN-C4A	5	13	22	25	M18
AA0042	下部電極 W-PN-C5A	6	13	22	25	M18
AA0043	下部電極 W-PN-C6A	7	13	22	25	M18
AA0044	下部電極 W-PN-C8A	9	13	22	25	M18
AA0045	下部電極 W-PN-C10A	11	17	27	30	M22
AA0046	下部電極 W-PN-C12A	13	17	27	30	M22

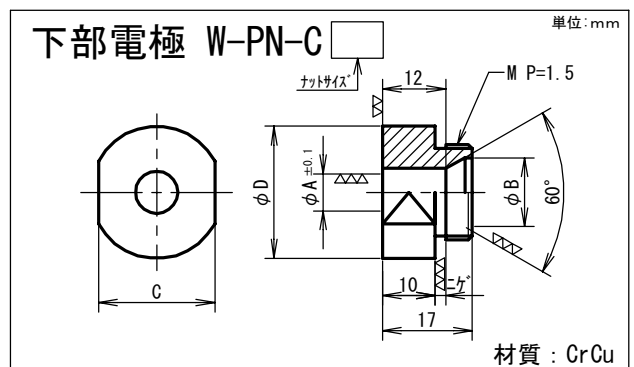

CDNo.	規格	A	B	C	D	M
AA0051	下部電極 W-PN-C4	5	13	22	25	M18
AA0052	下部電極 W-PN-C5	6	13	22	25	M18
AA0053	下部電極 W-PN-C6	7	13	22	25	M18
AA0054	下部電極 W-PN-C8	9	13	22	25	M18
AA0055	下部電極 W-PN-C10	11	17	27	30	M22
AA0056	下部電極 W-PN-C12	13	17	27	30	M22

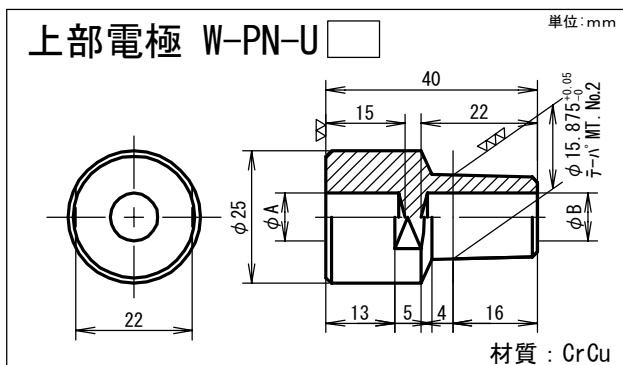

CDNo.	規格	使用ナット	A	B
JB2003	上部電極 W-PN-U3	M10/12	13	10
JB2004	上部電極 W-PN-U4	M6/8	9	9
JB2005	上部電極 W-PN-U5	M4/5	6	9

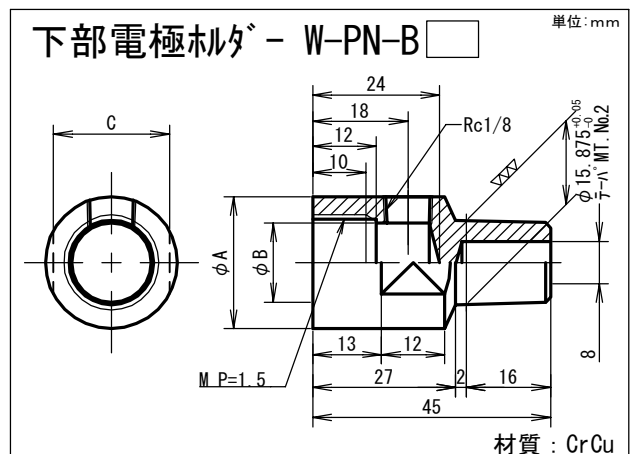

CDNo.	規格	A	B	C	M
AA2002	下部電極杓タ W-PN-B2	30	20	27	M22
AA2003	下部電極杓タ W-PN-B3	25	15	22	M18